

Ventus Standard unit automation

**Quick assembly, wiring and commissioning instruction
step by step**

table of contents

1	INTRODUCTION.....	3
2	INSTALLATION OF AUTOMATION COMPONENTS AND WIRING.....	3
2.1	POWER SUPPLY CIRCUITS FOR CONTROL PANEL COMPONENTS	3
2.1.1	Control panel power supply circuits	3
2.1.2	Power supply circuits for electric heater and optional equipment outside the VTS offer.....	5
2.2	CONTROL CIRCUITS - GENERAL INFORMATION	6
2.2.1	Connection diagram for the uPC3 driver and extension module	6
2.3	ANALOG AND DIGITAL (DISCRETE) CONTROL CIRCUITS.....	10
2.3.1	Installation and connection of temperature sensors.....	10
2.3.2	Connecting filter pressure switches.....	11
2.3.3	Connection of damper actuators (intake, exhaust, recirculation, by-pass).....	11
2.3.4	Connection of water heater antifreeze thermostat.....	12
2.3.5	Connection of controls for electric pre-heater and re-heater.....	12
2.3.6	Connecting control for optional devices outside the VTS offer (condensing unit, humidifier, etc.)	12
2.4	COMPONENTS WITH MODBUS COMMUNICATION	12
2.4.1	Wiring used for ModBUS communication	15
2.4.2	PCB EC extension module with ModBUS communication	15
2.4.3	Pressure transmitters with ModBUS communication	15
2.4.4	Humidity transmitters with ModBUS communication.....	17
2.4.5	CO2 transmitter with ModBUS communication	17
2.4.6	Inverters (frequency converters) with ModBUS communication (for fans and rotary heat exchanger).....	18
2.4.7	EC motors of fan sets and rotary heat exchanger with ModBUS communication	20
3	AHU OPERATION - GENERAL INFORMATION.....	20
4	THE FIRST LAUNCH OF AHU, CONFIGURING BASIC PARAMETERS.....	21
4.1	PRELIMINARY ACTIONS BEFORE STARTING AHU	21
4.2	AHU CONTROL WITH HMI ADVANCED	21
4.2.1	Description of buttons and elements of the main display screen.....	21
4.2.2	Logging in to the „Menu“ module.....	23
4.3	SETTING THE CONTROLLER APPLICATION CODES	24
4.4	ACTIVATION OF CONTROLLER INPUTS AND OUTPUTS	26
4.5	SENSORS CALIBRATION.....	27
4.6	OVERWRITING AND SIMULATING THE VALUES OF INPUT AND OUTPUT PARAMETERS OF THE CONTROLLER.....	27
4.7	CONFIGURATION OF COMPONENTS WITH THE MODBUS PROTOCOL	27
4.7.1	Checking the correctness of setting general communication parameters	28
4.7.2	Configuration of communication with inverters (in AHU with AC motors)	28
4.7.3	Communication configuration with fans equipped with EC.....	28
4.7.4	Programming EC motors	30
4.7.5	Configuration of communication with a rotary heat exchanger	31
5	USE OF AHU	32
5.1	SETTING THE OPERATIONAL PARAMETERS (TEMPERATURE, HUMIDITY, EFFICIENCY, ETC.).....	32
5.2	SWITCHING ON THE AHU, CHANGING THE OPERATING MODES	33
5.3	VIEWING CURRENT OPERATING PARAMETERS	34
5.4	ALARMS.....	34
5.5	SETTING THE WEEKLY CLOCK	34

1 Introduction

This manual is intended for customers who want to independently assemble, wire and commission the factory VTS automation in the new VENTUS STANDARD air handling unit. The manual applies only to air handling units with the configuration available in CCOL4, equipped with standard accessories offered by VTS, which do not require changing advanced parameters of the control system.

This manual may be helpful when assembling and commissioning the automation in control panels with unusual configurations or operating parameters, or cooperating with external accessories outside the VTS offer, but then it is necessary to use the advanced instruction manual available on the VTS website.

ATTENTION:

The ventilation unit control panel is a key element of the automation and is powered by dangerous voltage 230 / 400V, just like the fan motors and other components of the unit. Therefore, activities related to the assembly, wiring and commissioning of the said automation of VENTUS air handling units may only be carried out by authorized persons in the scope of assembly and operation of electrical devices in accordance with applicable regulations.

Independent assembly and commissioning of factory automation of VENTUS AHUs additionally requires basic knowledge in the field of automation of air handling units.

2 Installation of automation components and wiring

VTS factory automation is an optional equipment of offered control panels. Due to their wide functional diversity and the need to adapt the location of the control cabinet to the site conditions, the automation components are delivered to the customer separately for installation in the control panel at its final location.

Installation of automation components should be carried out by persons with appropriate qualifications and experience. Therefore, we will discuss only those elements that require special attention.

The wiring elements are out of the VTS scope of delivery, therefore, for the correct and safe functioning of the device, please strictly adhere to the recommendations as to the type and quality of these elements.

Installation of automation begins with determining the location of the power supply and control cabinet, which results from the object's conditions, the convenience of operating the control panel and the user's preferences. It should be remembered that the control wiring should not be too long to minimize the impact of interferences.

2.1 Power supply circuits for control panel components

2.1.1 Control panel power supply circuits

The control panel is powered by 1 x 230V / 50Hz or 3 x 400V / 50Hz voltage, depending on the load power. The cross-section of the power cable should be adapted to the maximum load current.

In the supply cabinet before the control panel, a circuit breaker should be used, adapted to the cable cross-section and control panel power, to meet the conditions of electric shock protection. The size of the short circuit protection in the preceding cabinet should be selected in accordance with the regulations by an authorized electrician. If RCCBs are used in the preceding cabinet, they must be adapted to operate with frequency converters.

Fan sets (with EC or AC motors), rotary heat exchanger motor and water heater pump are powered from the control panel. The control panel is equipped with overcurrent breakers to protect these

components. The cross-section of the power supply wiring for these components should be adapted to the load current. Pay attention to the correct connection of this wiring, especially the PE cable.

AC motors (if used) are powered via frequency converters. EC motors are equipped with integrated control systems. The power supply configuration of individual components for air handling units with AC or EC motors is shown in Fig. 1a and 1b, respectively.

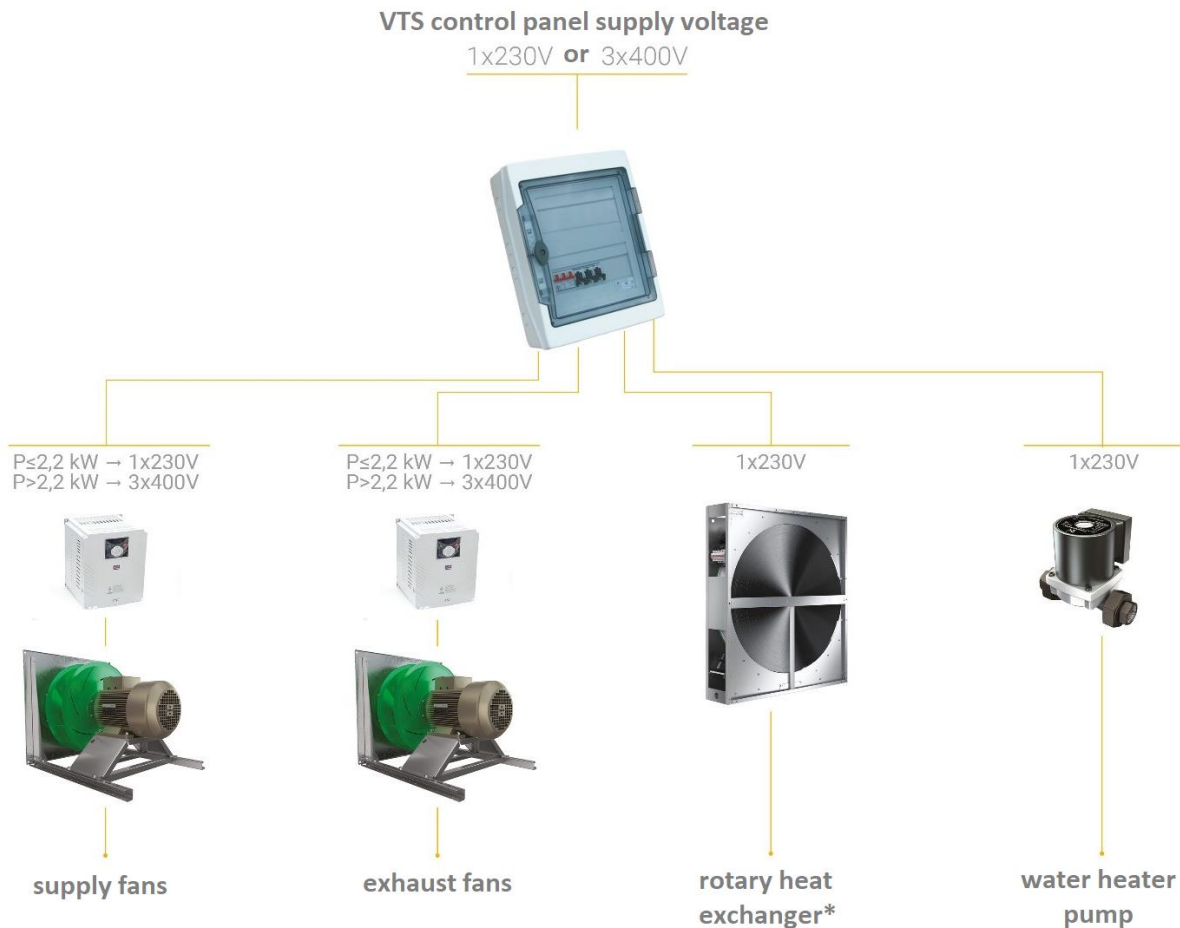

*) EC motor up to VENTUS VVS300, AC motor with inverter for larger units

*) up to the size of the VVS300 unit, the exchanger is driven by an EC motor, for size VVS400 and larger the exchanger is driven by an AC motor with an inverter

Fig. 1a Components supplied from the control panel (AHU with AC motors)

When using AC motors, frequency converters (inverters) should be installed in places not exposed to moisture and mechanical damage, as close as possible to the fan units (preferably outside, on the back of the fan sections), since the length of the cabling connecting the inverters to the motors should not exceed 10 m (detailed data can be found in the tech specs of inverters). In the case of external AHUs, the inverters should be installed in metal cabinets equipped with a heater and fan, controlled by a thermostat to ensure a temperature in the vicinity of the inverters between -10 ° C and + 40 ° C.

To connect the motors with frequency converters (inverters), shielded cables should be used with cross-section adapted to the load currents. The shield should be connected to the "PE" terminal in both inverters and motors.

To supply frequency converters (AC motors) or EC motor controllers use cables with 600V test voltage.

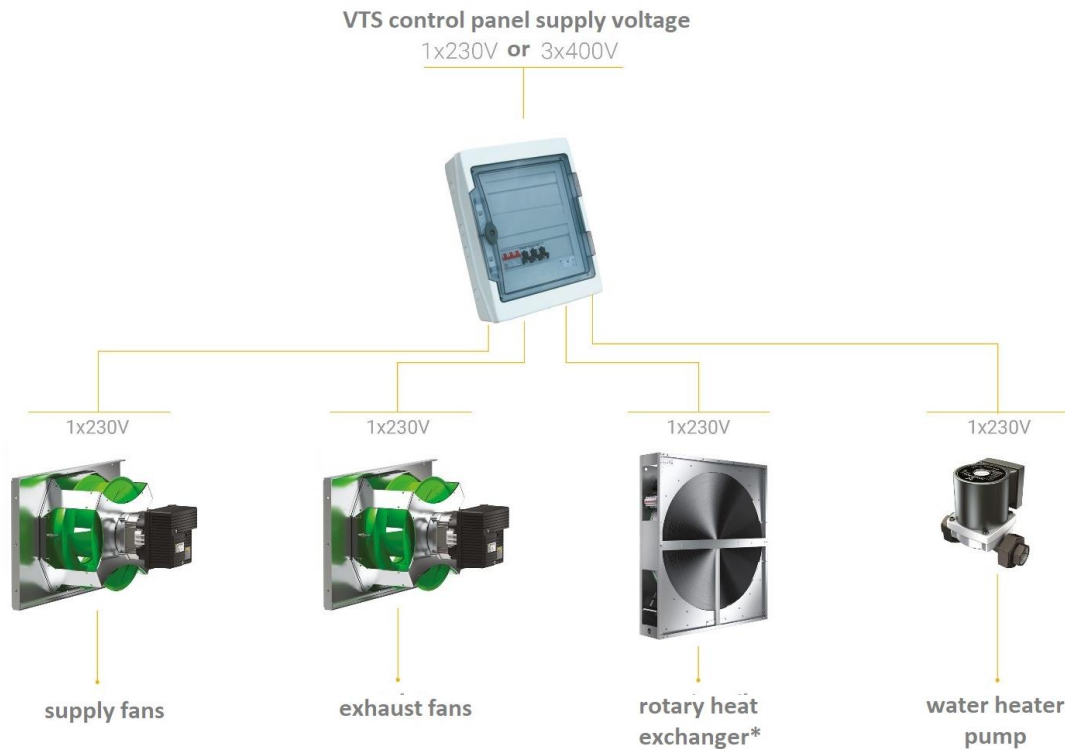

*) EC motor up to VENTUS VVS300, AC motor with inverter for larger units

Fig. 1b Components supplied from the control panel (AHU with EC motors)

2.1.2 Power supply circuits for electric heater and optional equipment outside the VTS offer

The electric heater and optional equipment outside the VTS offer (humidifier, refrigeration unit, etc.) require a separate cable for supply (Fig. 2). In the preceding power cabinet, overcurrent breakers should be used, adapted to the cable cross-section and heater power, so that the conditions of electric shock protection are met. Use a cable with a cross-section adapted to the maximum power of the heater, enabling the connection of a PE protective terminal.

Accessories and components outside the VTS offer should be connected in accordance with the documentation of these devices.

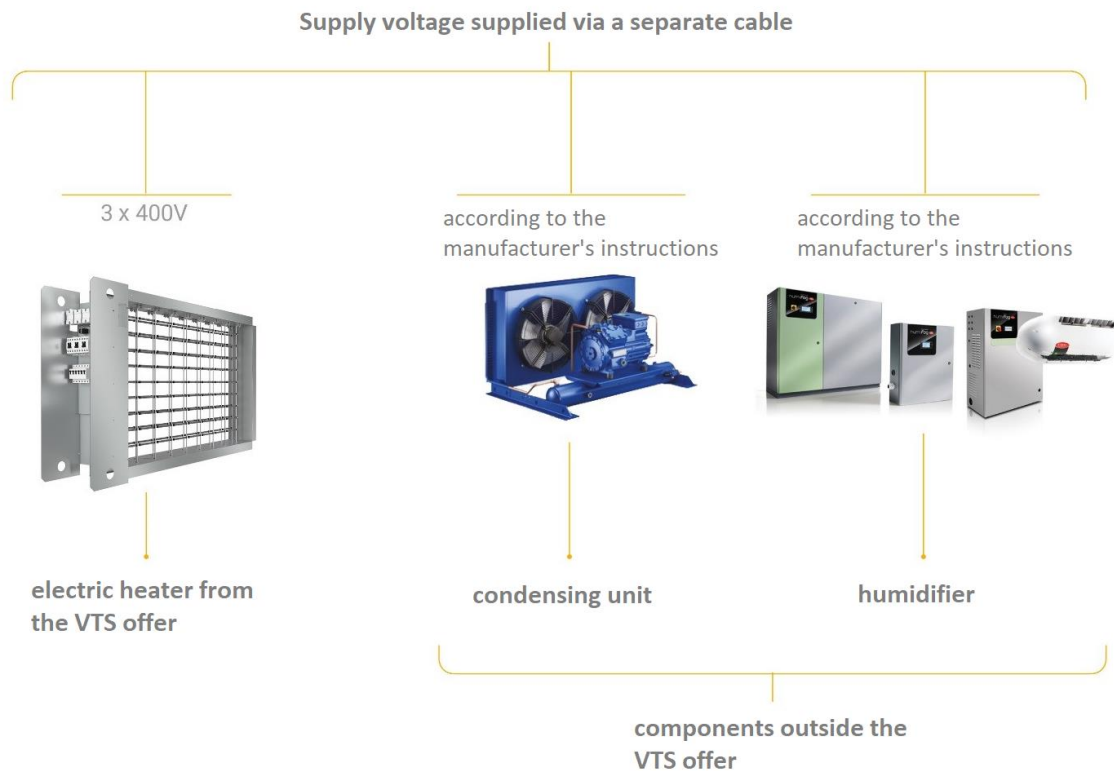

Fig. 2 Accessories requiring a separate power supply

2.2 Control circuits - general information

2.2.1 Connection diagram for the uPC3 driver and extension module

Individual automation components communicate with the controller either using analog and digital I/O, or using digital communication with the ModBUS protocol.

Some of the analog and digital inputs / outputs are implemented directly by the uPC3 controller and some via extension boards (e.g. PCB EC).

Graphic illustration of the signal assignment to individual electronic modules is shown in Figure 3.

ATTENTION:

·Depending on the application code entered, the controller dynamically sets the pin functionality. Thus, a single physical output can perform various functionalities, e.g. as many as six different tasks are assigned to two 0-10V analog outputs.

The reason for this solution is the universalism of VTS automation, enabling the use of the same controller for tens of thousands of types of applications. Lack of static assignment of signals to individual controller outputs prevents the publication of diagrams in the technical documentation available on the VTS website. The diagram is generated dynamically with the selection card. If required, it can be additionally generated by a sales representative or VTS Service Department.

Before starting the installation of the wiring, refer to the wiring diagram of the controller inputs and outputs provided with the AHU.

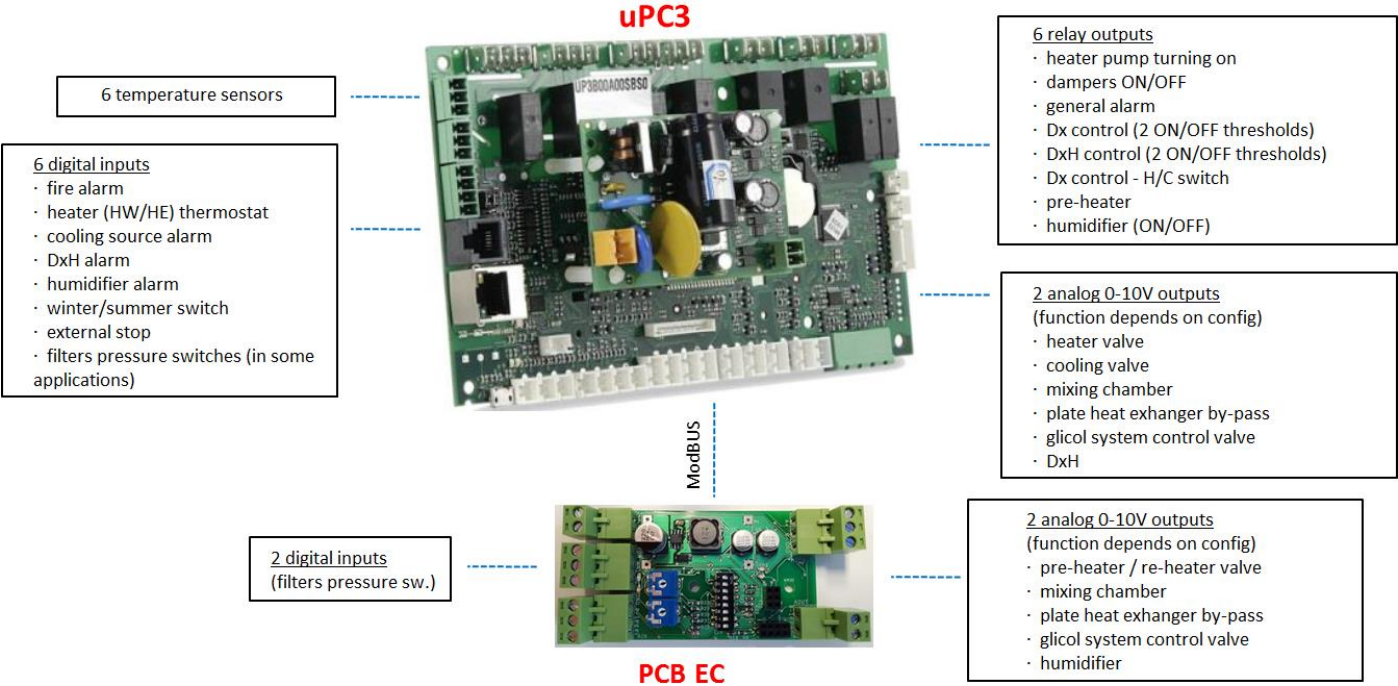

Fig. 3. Connection of analog and digital (discrete) I/O signals

Fig. 4 shows a general connection diagram for the uPC3 controller and PCB EC module.

Fig. 5 shows an example diagram of connecting the controller I / O signals for a specific application.

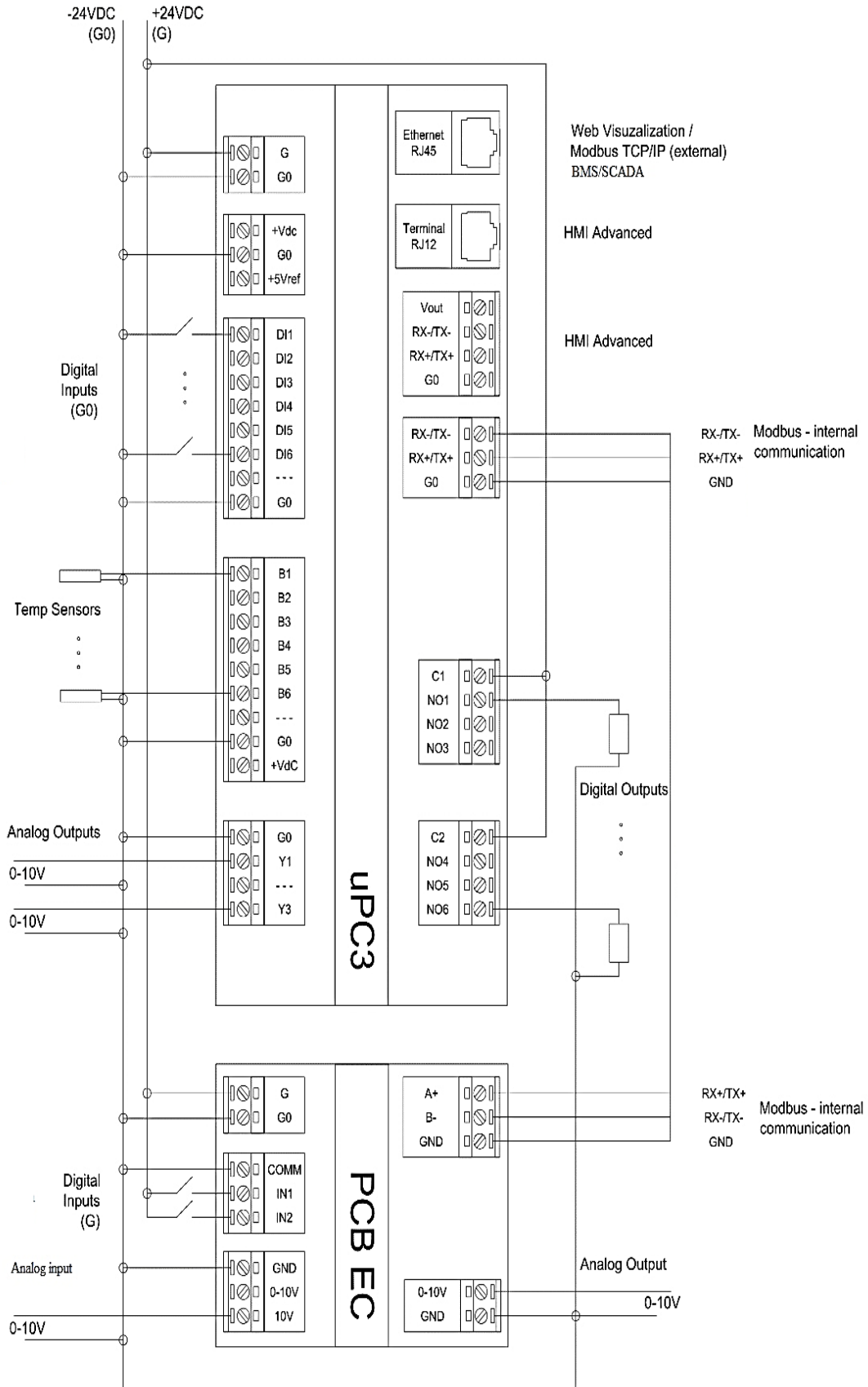

Fig. 4. Connection diagram of the uPC3 controller and PCB EC module

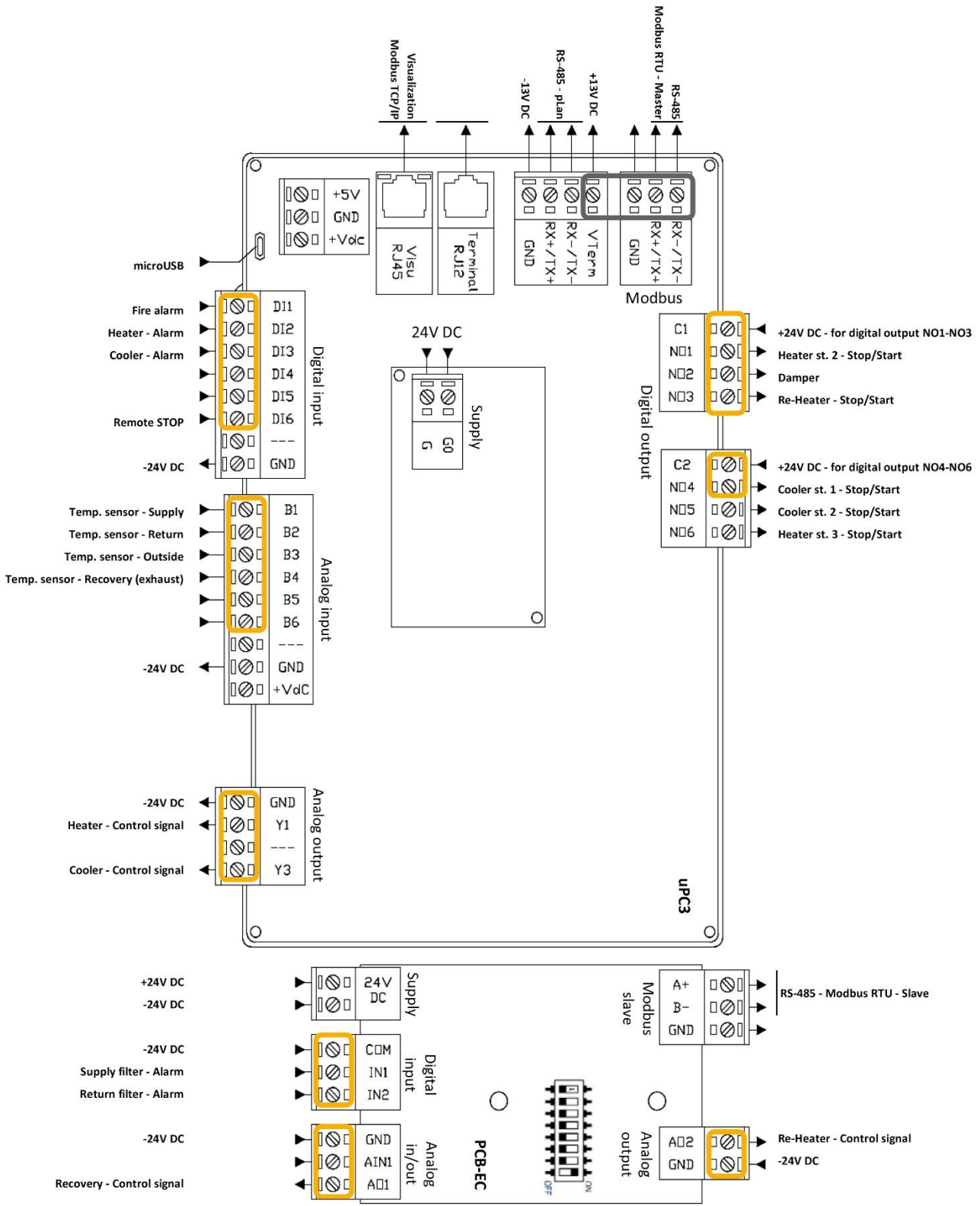

Fig. 5. Example diagram of signal connection to the uPC3 controller and PCB EC module for a control panel with FHPHCV / FVP configuration (application code AP|1|1|0|1|0|0|0|6|3|0|0|0|0|0|1)

2.3 Analog and digital (discrete) control circuits

2.3.1 Installation and connection of temperature sensors

Connect the temperature sensors to the controller using shielded cables with a minimum cross-section of 0.5 mm². Location of temperature sensors:

B1 – supply air temperature. Installation in the supply air duct, approximately 2 m behind the heater

B2 – temperature in the exhaust duct or as a room sensor (cable length not greater than 100 m)

B3 – outside temperature in the intake duct

B4 – sensor responsible for protecting the heat recovery exchanger from frosting - location depends on the type of exchanger. Particular attention should be paid to the correct location of the temperature sensor protecting the rotary heat exchanger (Fig. 6). Incorrect location of this sensor may lead to reduced AHU efficiency.

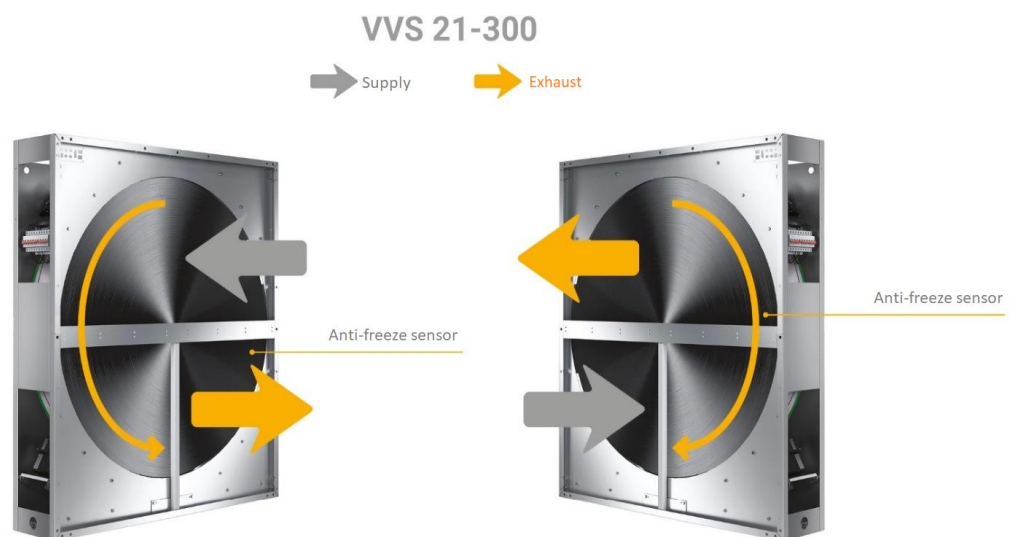

Fig 6a. Location of B4 sensor behind the rotary heat exchanger for the supply air track at the top or bottom of the unit – AHU size from VVS21 to VVS300.

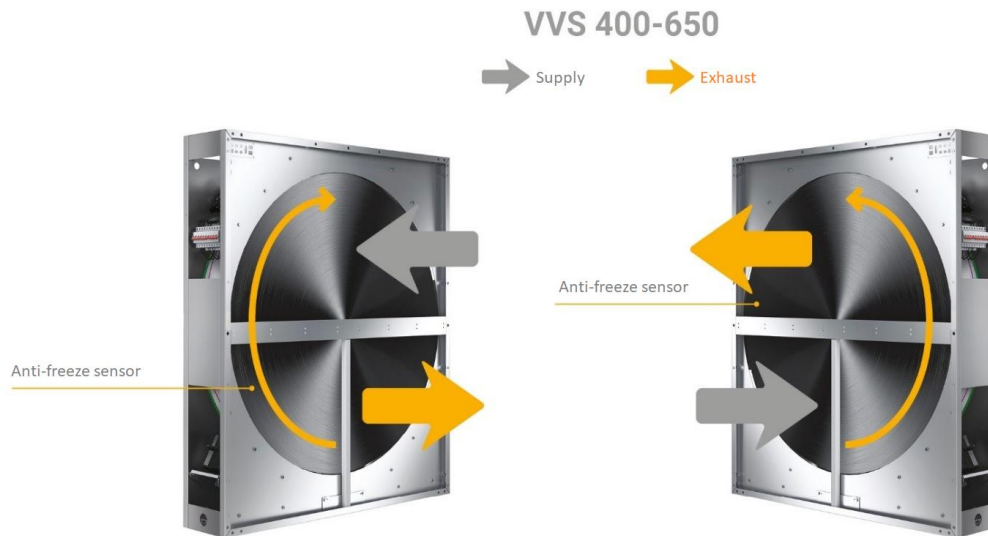

Fig 6b. Location of B4 sensor behind the rotary heat exchanger for the supply air track at the top or bottom of the unit – AHU size from VVS400 to VVS650.

B5 – contact sensor, mounted on the return pipe from the water heater. It is a method of protecting the heater against freezing using the measurement of the return temperature of the heating medium and it is possible to use it in quality control systems of the heater power (with a pump in a short heater cycle).

B6 – supply air temperature at the outlet after heat recovery.

2.3.2 Connecting filter pressure switches

Pressure switches should be installed in a place enabling service access. The pressure setting should correspond to the final pressure of the filter from the selection card. Make sure that the rubber tube from the filter inlet is connected to the pressure switch stub marked "+" and from the outlet to "-". The control cable should be connected to the normally closed contacts of the pressure switches.

2.3.3 Connection of damper actuators (intake, exhaust, recirculation, by-pass)

The VTS automatics use actuators powered with 24V (safe) voltage. In air handling units with a mixing chamber, the intake, exhaust and recirculation damper actuators are controlled by a 0-10V signal, common for all 3 dampers. In air handling units without a mixing chamber, the intake and exhaust dampers are controlled by a 24V (ON / OFF) signal, common for these dampers. By-pass damper actuators for plate heat exchangers and actuators for control valves are controlled by 0-10V signals.

2.3.4 Connection of water heater antifreeze thermostat

The antifreeze thermostat is an optional protection of the water heater. It should be used with the quantitative method of heater power control. In the case of qualitative control of the heater power, the anti-freezing thermostat can be used in parallel or interchangeably with the recommended method of measuring the heating medium return temperature.

The thermostat's capillary should be stretched over the largest possible surface of the heater on the air outlet side. The thermostat must be installed in a place with service access. The temperature setting should be between 3 and 5 degrees, with a hysteresis of 5 degrees.

The control cable must be connected to the thermostat normally closed contacts..

2.3.5 Connection of controls for electric pre-heater and re-heater

The electric heater can be used as a re-heater to heat the supply air to the required temperature or as a pre-heater to protect the heat recovery exchanger against frosting - then it is installed in the supply air track before the heat recovery exchanger and its task is to heat the air to a temperature of about -5 ° C in the case of plate heat exchangers and to about -13 ° C in the case of rotary heat exchangers.

Attention:

The electric heater is powered from an external source with a separate cable, regardless of the automation option (see section 1.1.2 of this manual).

Options:

In compact and standard AHUs ordered with VTS automation, electric heaters are equipped with modules of smooth power control with short-circuit protection of individual heater sections. Connect the heater power control cable and the safety thermostat cable to the control panel terminal.

If the unit is ordered without automation, the scope of delivery includes a heater without a control module and a short-circuit protection. These elements should be completed by the customer.

2.3.6 Connecting control for optional devices outside the VTS offer (condensing unit, humidifier, etc.).

To control the operation of the cooling / heat sources supplying the Dx and DxH heat exchangers, shielded cabling should be used, enabling the transmission of 2 potential-free signals + 0-10V signal (start + H / C switch + 0-10V signal or start of 1 and 2 sections). A total of 6-wire cable with a minimum cross-section of 0.5 mm² at length up to 50 m). The analog signal can be scaled individually to the needs of the aggregate (e.g. 0-10V heating / cooling; 0-5V cooling, 5-10V heating; etc.).

VTS automation can fully take over control of the humidification process, including the control of maximum humidity in the supply channel. Optionally, the VTS automation can only provide a signal confirming the operation of the unit, leaving the humidity control for the autonomous humidifier automation.

2.4 Components with ModBUS communication

All components communicating with the controller via the ModBUS RTU protocol should be connected into one common network and connected to the terminals marked as "RS-485 Master" in the diagram (fig. 4 and fig. 5 of this manual). The "RS-485 -plan" port is not used. It is connected in parallel with the RJ12 connector (HMI Advanced connection).

The ModBUS RTU protocol is also used for communication between the controller and expansion boards, increasing the number of digital and analog inputs / outputs.

Fig. 7 shows the set of accessories with ModBUS communication, together with the addresses assigned to them.

The addresses of fan motors depend on the type of unit and the number of fans installed in it. The addresses given in the diagram refer to standard AHUs. In the case of units with FanWall type fans (e.g. in Ventus Compact units), the addresses of individual fans will be different. Similarly to analogue I / O, please refer to the diagram generated for the specific application code (supplied with the control panel.)

All components that we want to connect to the ModBUS network must be set to the correct baud rate, parity and stop bit compatible with this network. They must also have relevant parameters assigned to the appropriate registers.

Therefore, it is recommended to use components recommended by VTS, factory prepared for cooperation with this network.

Each of the components connected to the network should have in its controller an individual address by which the control panel controller identifies it in the network. First, set the addresses of sensors and transducers, then the inverters (if installed in the control panel) and finally the EC motors that are programmed with the control panel controller. Detailed instructions for configuring addresses in individual components are provided later in this documentation.

The addresses of the controller output and input extension modules and the addresses of fans depend on their number and type of the AHU. Therefore, in order to identify them, refer to the scheme generated individually for a specific application code, supplied together with the unit.

The addresses of pressure, humidity and CO2 transducers have fixed values assigned in the controller and should not be changed.

The "Mainboard" module (Adr. 18) and the "I/O module" (Adr. 15) are not used in standard AHUs - the option is available in selected regions and models. They were included in the specification (Fig. 7) for information purposes only.

Installation and commissioning instructions for Ventus AHU automation

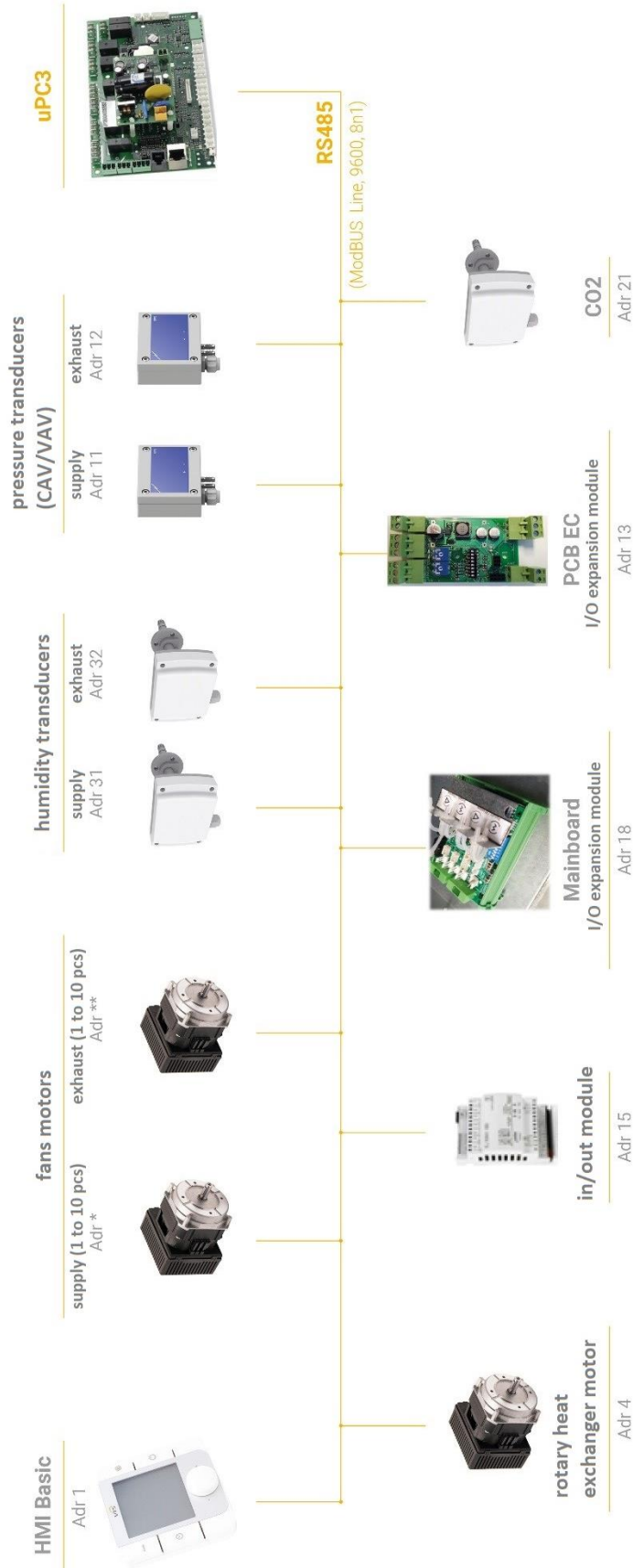

*) depends on motors number, in order Addr 2, 5, 7, 9 (for FanWall Addr 41, 42, 43, 44, 45, 46, 47, 48, 49, 40)

**) depends on motors number, in order Addr 3, 6, 8, 10 (for FanWall Addr 51, 52, 53, 54, 55, 56, 57, 58, 59, 50)

Fig. 7. Connecting accessories with ModBUS communication.

2.4.1 Wiring used for ModBUS communication

Use cabling in accordance with the ModBUS RTU protocol standard. It is recommended to use a twisted pair shielded Li2YCY cable. Two wires will be used for communication, two to power the transmitter or as a reserve. Starting from the uPC controller, common wiring should be routed from component to component, avoiding as much as possible the „star” connection. If the control cabinet is mounted right next to the control panel, the network is not very extensive and deviations from this rule usually do not cause complications.

2.4.2 PCB EC extension module with ModBUS communication

The standard AHUs use the PCB EC output expansion module with fixed address No. 13 set in the program of the controller. The controller functionality is set with microswitches and for the application as the expansion module only the eighth switch should be in the „on” position, as shown in Fig.8 .

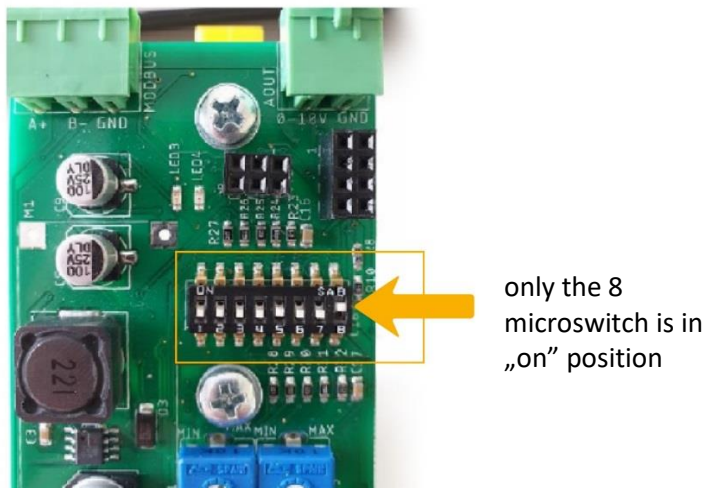

Fig. 8. Location of microswitches in the PCB EC module.

2.4.3 Pressure transmitters with ModBUS communication

The pressure transducer should be installed in a way that allows later service access to the inside of its housing. The method of connecting the hoses marked (+) and (-) on the transmitter housing is shown in Fig. 9.

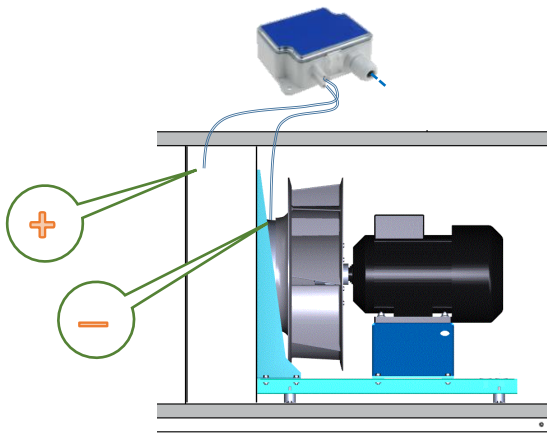

Fig. 9. Connection of a pressure transducer (CAV function).

Addresses of pressure transducers offered by VTS are set with microswitches inside their housing. The addresses of these components should be set before switching on the AHU supply voltage.

Both pressure transducers are delivered with factory set address No. 11, suitable for air supply. In the transducer mounted in the exhaust section, the address should be changed from 11 to 12, as shown in the figure below.

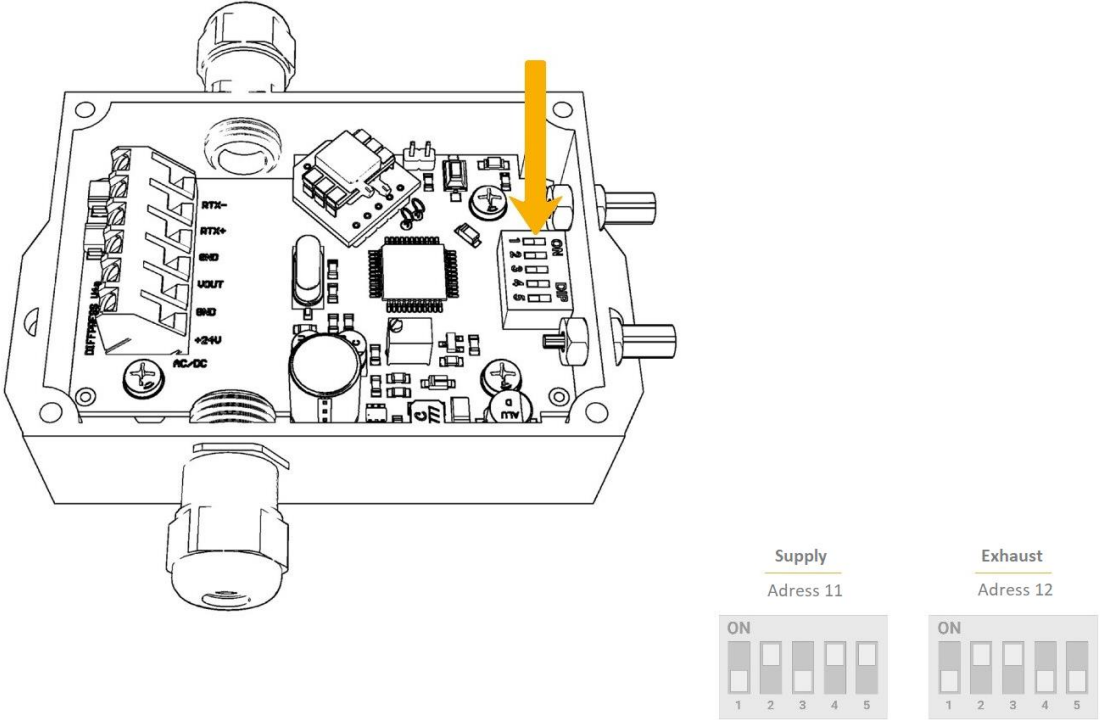

Fig. 10. Setting the pressure transducer addresses (CAV function).

2.4.4 Humidity transmitters with ModBUS communication

Addresses of humidity transducers offered by VTS are set with microswitches inside their casing. The addresses of these components should be set before switching on the AHU supply voltage.

Both humidity transmitters are delivered with factory set address No. 31, suitable for air supply. In the transducer mounted in the exhaust section, the address should be changed from 31 to 32, as shown in the figure below.

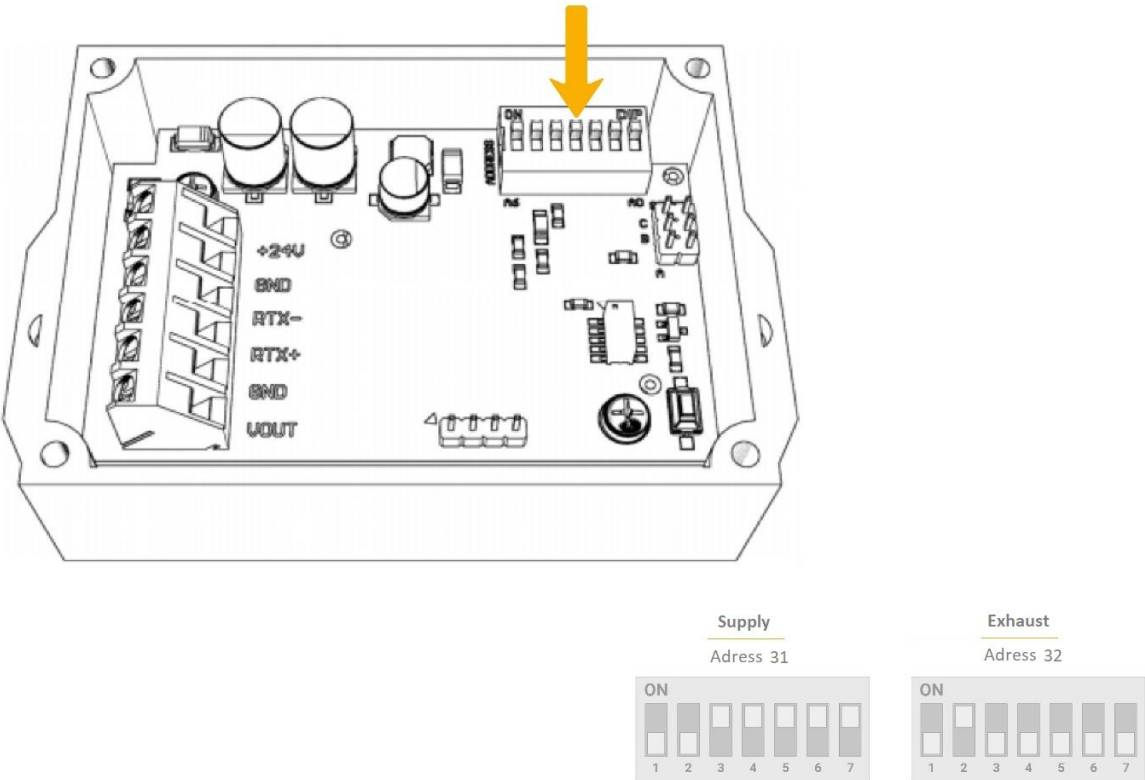

Fig. 11. Setting the addresses of humidity transducers.

2.4.5 CO2 transmitter with ModBUS communication

The address of the CO2 transmitter, which is in the VTS offer, is set with microswitches inside its housing. This address should be set before switching on the AHU supply voltage.

The correct CO2 transmitter address is 21.

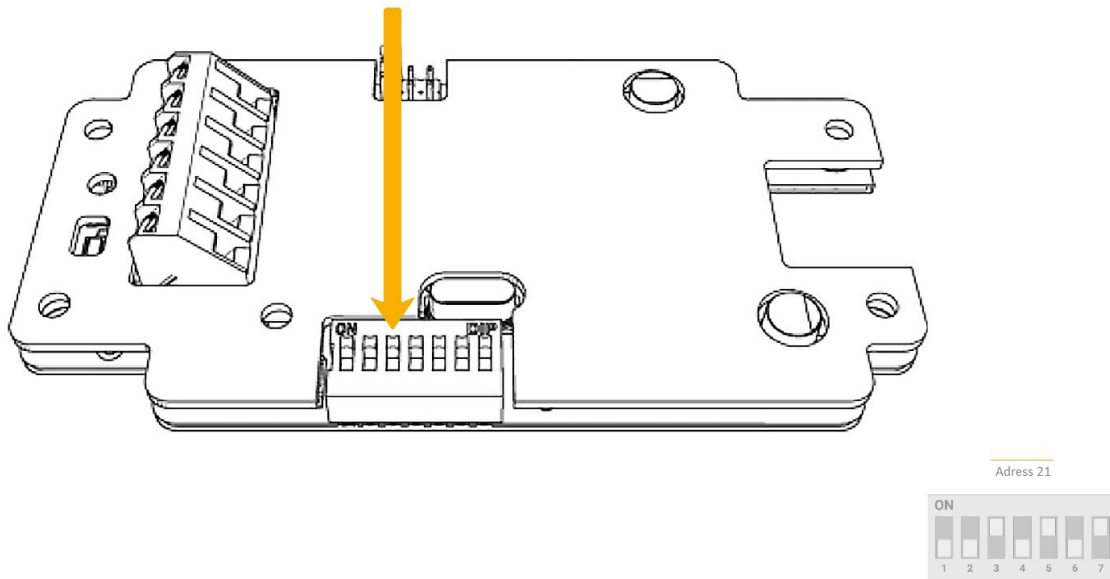

Fig. 12. Setting the CO2 transmitter address

2.4.6 Inverters (frequency converters) with ModBUS communication (for fans and rotary heat exchanger)

Inverters are programmed directly from their control panels, regardless of the AHU controller. The inverters are factory set to the same default addresses, so to avoid conflict, the programming process must be carried out individually for each of them, with ModBUS communication disabled.

The inverters are programmed in accordance with the instructions, where parameters which value should be set are listed. Other parameters not listed in the table retain the factory default values and should not be changed.

The I60 parameter is used to set the addresses of individual inverters. The correct values should be confirmed on the individually generated scheme with the selection card.

Parameter **H32** should be calculated according to the formula:

$$\mathbf{H32 = (1 - H31 * rotary\ speed/6000) * 50\ Hz}$$

Frq and I24 parameter settings are different for IC5 and IG5A inverters, which is why they are listed in separate tables.

IC5 inverter			
Parameter	Code	Value	Comments
P5 input function	I24	19	External emergency shut down - NC
Frequency setting method	Frq	8	ModBUS-RTU communication

IG5A inverter			
Parameter	Code	Value	Comments
Frequency setting method	Frq	7	ModBUS-RTU communication

LG inverter			
Parameter	Code	Value	Comments
Acceleration time	ACC	45	reccomended value 45 sec
Deceleration time	DEC	45	reccomended value 45 sec
Stop type	F4	0	factory settings deceleration
Maximum work frequency	F21	80	Hz
Nominal motor frequency	F22	50	Hz
U/f characteristic type	F30	1	square characteristic
Motor thermal protection	F50	1	on
Number of motor poles*	H31	*	from 2 to 12
Nominal motor slip*	H32	*	0.01 Hz default
Nominal motor current*	H33	*	
Motor current without load*	H34	*	0.1 A default
Gain for speed display*	H74	*	1 default
Control type Start/Stop	Drv	3	RS 485 communication
Inverter adress	I60	2	supply fan
Inverter adress	I60	3	exhaust fan
		5	supply fan 2
		6	exhaust fan 2
		7	supply fan 3
		8	exhaust fan 3
		9	supply fan 4
		10	exhaust fan 4
		2	stop after characteristic
Control signal loss reaction	I62		
Waiting time after control signal loss	I63	30	reccomended value 30 sec

After programming the inverters, it will be required to configure communication in the AHU controller. This operation should be performed after programming all other controller configuration parameters. The procedure is described in this manual in chapter 4.7.2 for fans and in chapter 4.7.4 for rotary heat exchangers.

2.4.7 EC motors of fan sets and rotary heat exchanger with ModBUS communication

The motors are factory set to the same ModBUS addresses, so to avoid address conflicts, they should remain off until they are programmed. Configuring the operating parameters of EC motors is done in the software via the AHU controller. So we have to become familiar with its operation. The programming procedure is described in chapter 4.7.3 of this documentation.

3 AHU operation - general information.

Current control panel operation is possible with one of two operator panels - HMI Basic or HMI Advanced, or with visualization tools, factory implemented in the controller (function available as a standard) or implemented using BMS (option - VTS provides variables to an external system that is outside VTS offer).

The AHU operation options are presented in Fig. 13.

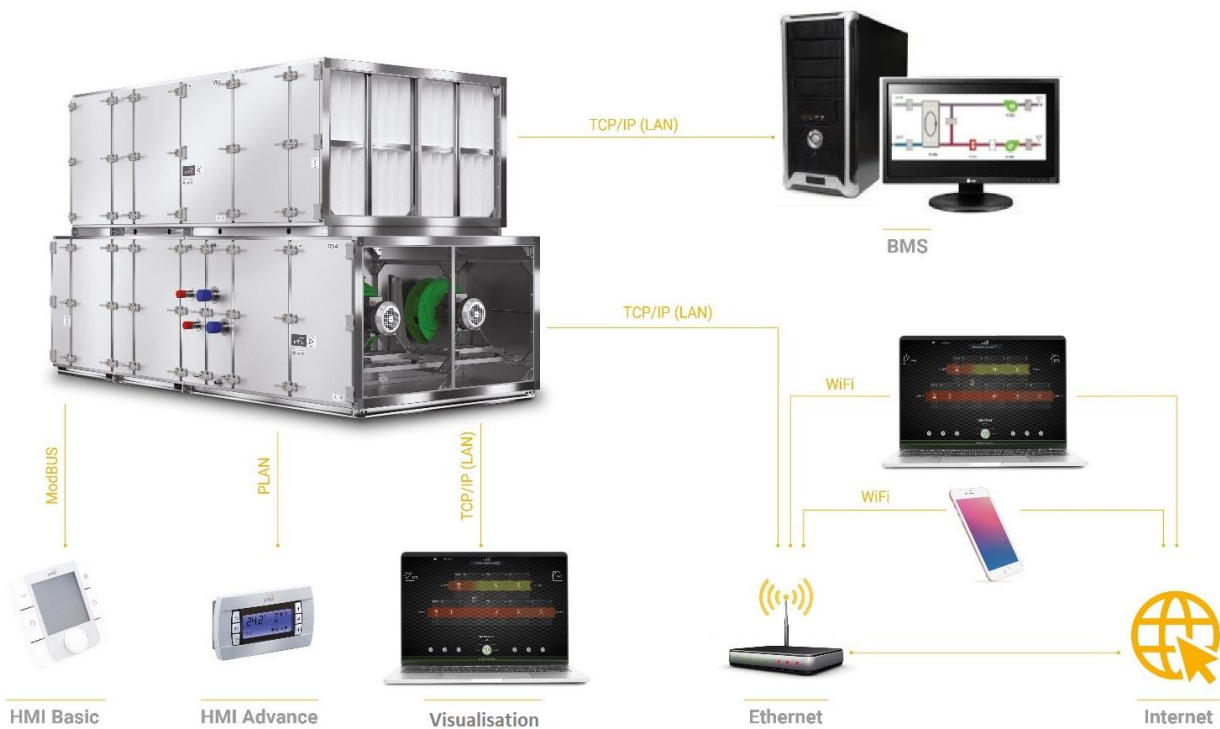

Fig. 13. Operating options of the VENTUS AHU controller.

The HMI Advanced panel additionally enables full service support, including changing all AHU configuration parameters. In addition to the physical panel, connected directly to the controller, you can use a virtual panel, available in the standard visualization, which can be displayed on a computer or mobile device. The virtual panel plays the role of a remote desktop of the physical panel and is an accurate representation of all its functions and information displayed on it.

It can be used with or without a physical panel (with the physical panel disconnected). The operation of the HMI Advanced panel is described in chapter 3.2 of this manual. The way of connecting the computer to the controller in order to start the visualization is not difficult. You can watch it on the video broadcast on YouTube or read in the quick start instructions for connecting your computer, available at www.vtsgroup.com.

4 The first launch of AHU, configuring basic parameters

4.1 Preliminary actions before starting AHU

The necessary preparations must be carried out before starting AHU.

Before switching on the AHU, make sure that the control cabinet is correctly connected to the power supply. To do this, make sure that all circuit breakers (fans, automation, rotary heat exchanger motor) are turned off.

In the preceding power cabinet, switch on the voltage supplying the control panel tweeter and measure the value of this voltage on the AHU supply cable terminals. Follow these steps when this voltage is within the allowable limits (207 to 241V for single-phase supply or 380 to 420V for three-phase supply).

When everything is OK, turn on the AHU main switch (with the fan, pump and rotary heat exchanger fuses off). Wait a moment for the system to initialize. The HMI Advanced operator panel must be used to configure and first start AHU. You can use the physical panel connected directly to the control panel or the virtual panel displayed on your computer screen. To connect the computer and display the virtual panel, refer to the manual at www.vtsgroup.com.

4.2 AHU control with HMI Advanced

After turning on the AHU and initializing the system, the HMI Advanced display will show the screen as below.

4.2.1 Description of buttons and elements of the main display screen

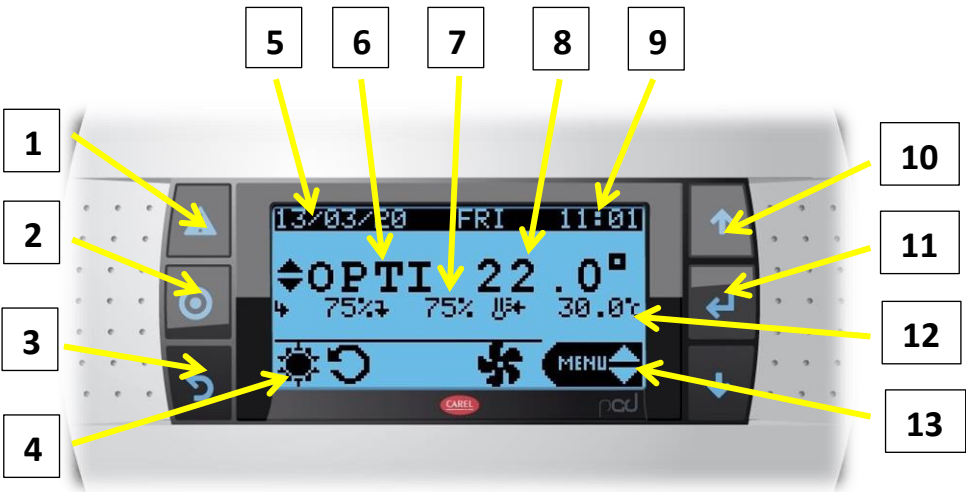

1. "Alarm" button (triggering active and archived alarms, clearing alarms). When the alarm is active, the button is illuminated in red.
 2. Button for changing the operating modes (OFF / Auto / Low / Eco / Comfort). Confirmation with "Enter"
 3. "ESC" button (return to previous field or screen)
 4. Status of the air handling unit (fan operation / stop, heating / cooling, activation of heat recovery, alarm, manual stop, etc.)
 5. Current date
 6. Current operating mode
 7. Current fan control
 8. Current value of the leading temperature
 9. Current time
 10. Arrows to navigate up and down and to change parameter value
 11. "Enter" button. Selecting the parameter to be changed, confirming the selected value.
 12. Set value of the master temperature
 13. Icon informing about readiness to choose one of the three HMI operating modules (Info / Set / Menu). Changing the module with the arrow buttons, confirming with the "Enter"
- "Info" module (preview of the control panel operation status - available without logging in)
 - "Set" module (changing the settings of user parameters: performance, temperature, humidity, CO2 and setting the timer - available without logging in)
 - "Menu" module (enables the introduction of configuration changes to the AHU and its components as well as programming of EC motors, available only after logging in)



Some screens hide when not active.

4.2.2 Logging in to the „Menu“ module

In order to carry out any AHU configuration changes, we must log in to the controller "Menu" module.

Use the arrows to select the "Menu" module and confirm with "Enter".

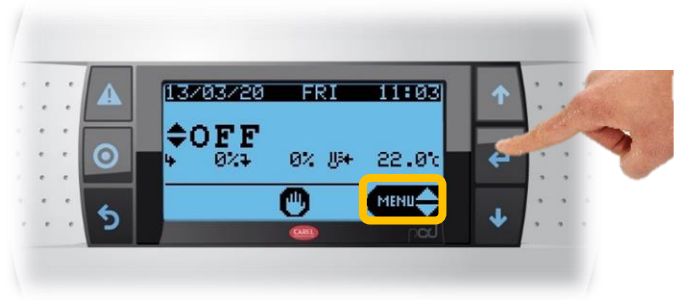

Clicking the 'Enter' button several times and then the upper arrow set the access code to 0002. Confirm with the 'Enter' button.



The main menu is divided into parts, separately for heating, cooling, fans, heat recovery, recirculation, input and output settings as well as main AHU configuration settings and other parameters. The appropriate submenu is selected with the arrows and confirmed by pressing "Enter".



Each submenu consists of several screens. For convenience of navigation, the individual screens of each submenu are numbered. Move between them using the arrows when the cursor is in the upper left corner of the screen. In order to go one level higher, press the "Esc" button.

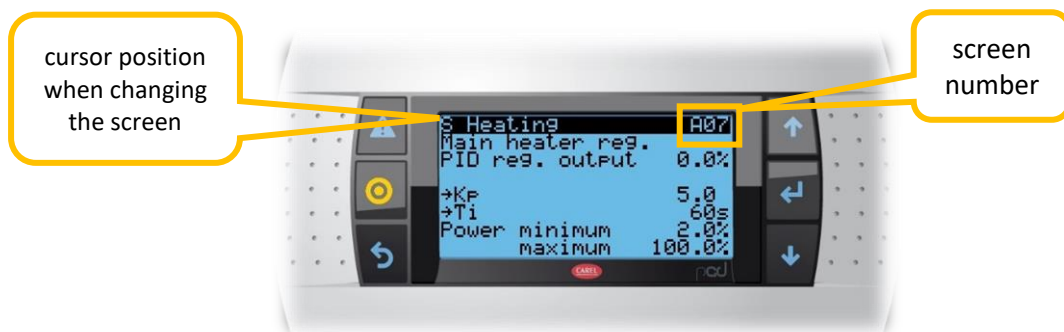

4.3 Setting the controller application codes

We start the operations related to the first start-up by entering the control panel application code. Remember that until the controller parameters are configured, the short-circuit protection of the fans (EC motors or inverters), the rotary heat exchanger and the heater pump should be off.

Log in to the "Menu" module and go to the "I." Configuration"

Before changing the application code, you must put the AHU into programming mode. On the I02 screen, you must change the value of the "Enable to work" from "YES" to "NO". Confirm with "Enter".

Then set the application code from the AHU selection card on the first screen of this submenu (I01). The code should include information about whether HMI Basic is connected. HMI Basic should be disconnected before completing the complete configuration of the control panel. If it will be used for current operation, then after finishing the AHU programming, change the setting of the last digit of the application code to "3".

Fig. 14 provides an explanation of the individual code entries.

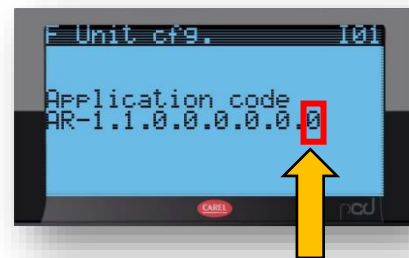

„0”, when there is no HMI Basic,
„3”, when there is HMI Basic

2019 automation
programming

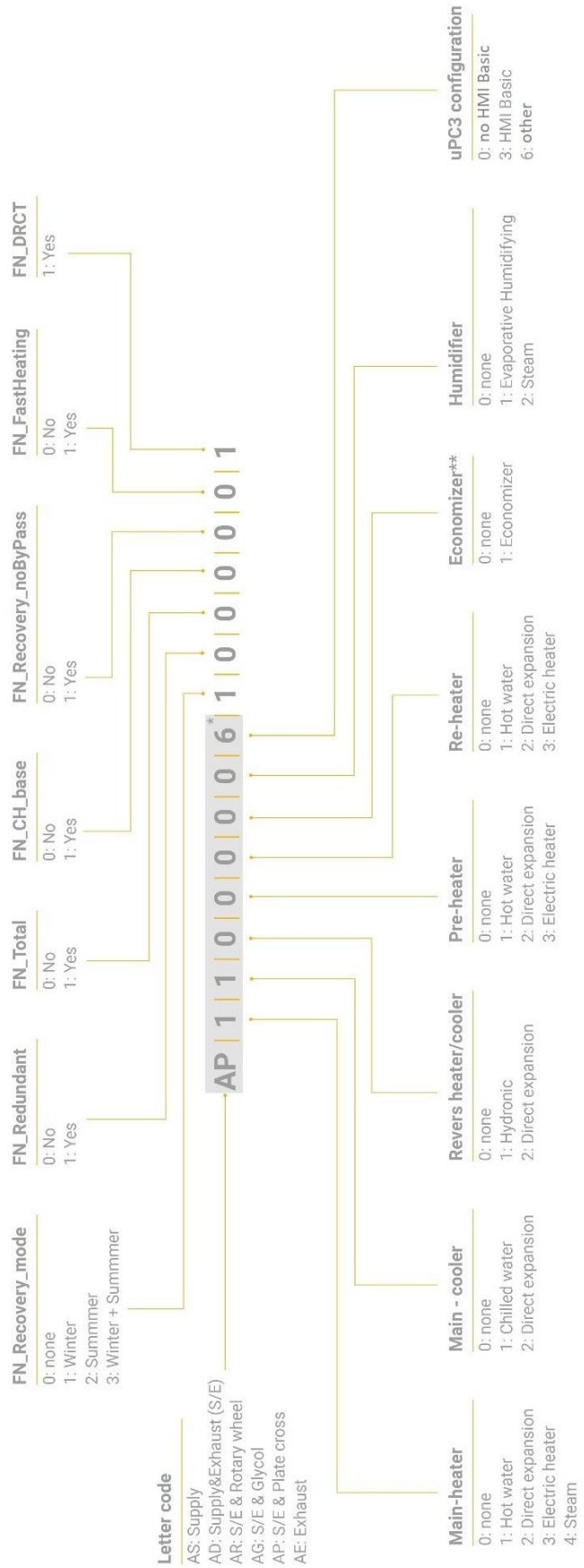

*) the marked part of the code is set using HMI Advanced on the I01 screen, the rest of the code is not displayed and is set in different parts of the menu
**) recirculation damper

Fig. 14. Meaning of individual characters of the application code

After entering and confirming the code, change the "Running" parameter on the I02 screen from "NO" back to "YES".

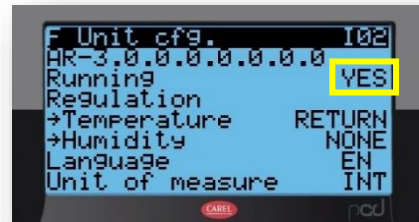

On this screen we also choose which temperature is the leading temperature - exhaust or supply air ("temperature control"), we can also activate humidity control ("Humidity control"), select the language for the service menu ("Language") and region for units of measurement (for Poland the correct setting is "INT"). Each change is confirmed by pressing "Enter".

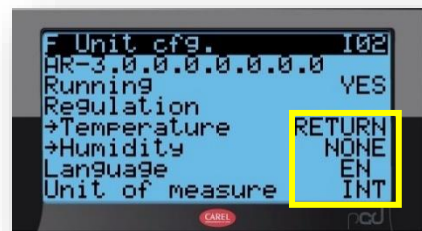

4.4 Activation of controller inputs and outputs

All controller inputs (sensors, transducers, components with ModBUS protocol) can have the status "active" (the controller identifies them in the system) or "inactive" (the controller ignores their presence). Setting the application code pre-configures the inputs and outputs of the controller, but some of them require manual activation.

Some of the signals are supported by extension modules, in our example the PCB EC. Go to screen J03 to confirm its activity.

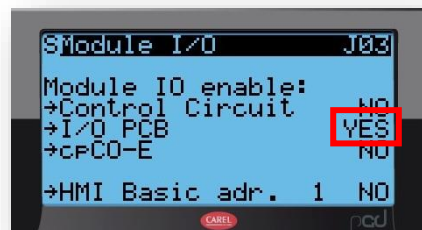

The parameter "Module I/O PCB" should be set to "YES". Other modules and "HMI Basic" should be set to "NO".

Then go to the "G" submenu. Screens G01, G02 and G03 are used to activate or deactivate the other controller inputs. Check the correctness of each setting according to the scheme generated in CCOL for your AHU to exclude incorrect program operation. For example, you can change the status of a contact sensor for the heating medium temperature on the G01 screen (example shown on the screen).

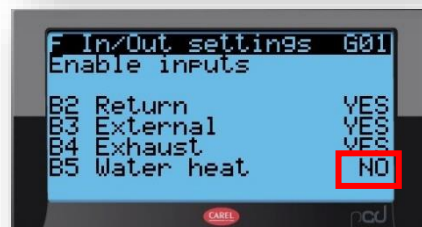

4.5 Sensors calibration

G05 and G06 screens are used to calibrate sensors and transducers. The differences in the sensor indications may result from the length of the cables used and other mounting conditions, which is why we recommend performing the calibration process the first time you start AHU. Confirm the controller indication with an independent instrument and enter the correction value in the AHU controller. The values of the measured parameters will take into account the positive or negative correction we have made. The entered correction values are confirmed with the "Enter" button.



4.6 Overwriting and simulating the values of input and output parameters of the controller

Screens G07 to G16 are used to manually overwrite digital and analog input and output parameters of the controller (simulating their values). This functionality allows you to test the correct operation of the controller during service work, it can also be useful for manually setting signals in an emergency situations.

Digital signals are changed on screens G07 to G11 by changing the contact logic "NC" to "NO" and vice versa.



Analog signals are changed on the screens by entering the parameter value (variable), expressed as a percentage. This also applies to temperatures for which 0% corresponds to -50°C, 100% corresponds to +100°C.

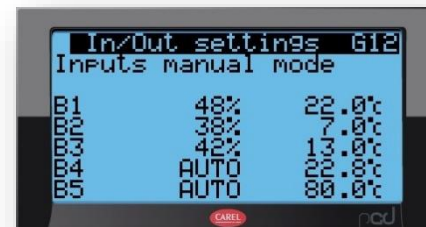

ATTENTION:

We must remember that during normal AHU operation all settings on these screens should be inactive.

4.7 Configuration of components with the ModBUS protocol

All components, except EC motors, communicating with the controller via ModBUS protocol (pressure, humidity and CO2 transducers, inverters) should be configured before the first start-up of AHU (details are discussed in chapter 1.4 of this documentation). For further actions it is necessary to check the communication parameters of the controller itself.

4.7.1 Checking the correctness of setting general communication parameters

We check whether the correct general communication parameters are set in the controller (screen "I07"). The correct value for the "Baudrate" parameter is 9600.



4.7.2 Configuration of communication with inverters (in AHU with AC motors)

The inverter programming steps are described in chapter 2.4.6 of this manual. Before connecting the ModBUS cabling to them, we must make configuration changes in the AHU controller.

After logging in to the "Menu" module, go to screen I03, where we set the type of inverters, independently for supply and exhaust fans.

On the same screen we set the type of control (CAV, VAV or NONE - fixed frequency) and the number of supply and exhaust fans.

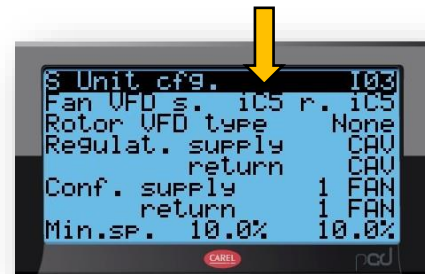

Then set the address of each inverter (screen "I41"). The inverters of the supply fans are marked with the letter "s" and those with extractors the letter "r". Each inverter is described by two numbers: the first one specifies the fan number in the set, the second one the address in the ModBUS network.

The addresses of each fan should be confirmed in the diagram generated together with the AHU selection card. In our example below, engine 1 has address 2, engine 2 has address 5.

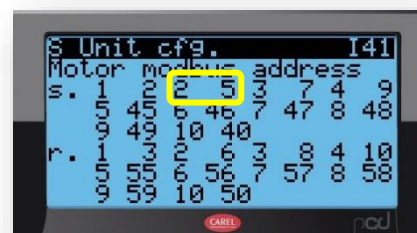
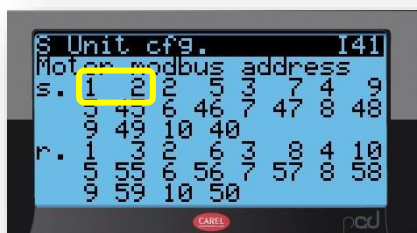

After configuring the last inverter, connect the communication cable to each of the inverters individually and check whether communication between the inverter and the controller is correct (does the driver "see" the inverter and whether both devices do not report errors).

4.7.3 Communication configuration with fans equipped with EC

In the case of fans with EC motors, programming of their parameters, including address assignment, is done from the level of the uPC3 controller.

We start the configuration from the screen "I03", in which we set the type of motors separately for supply and exhaust fans. On the same screen in the following lines we set the type of control (CAV, VAV or NONE - fixed frequency) and the number of supply and exhaust fans.

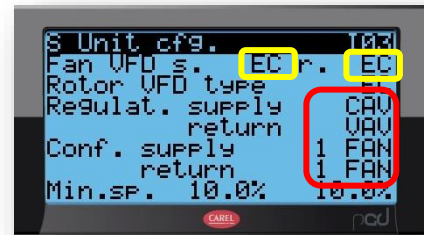

We go to the "I04" screen. We set the fan power according to the selection card.

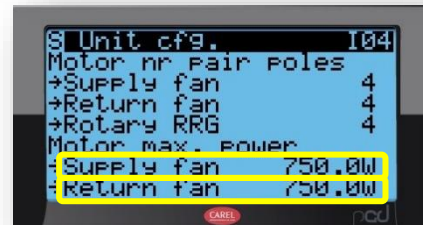

Then we check the address settings of each engine (screen "I41"). The procedure is identical to that described in chapter 4.7.2. for AC motors equipped with inverters. The motors of the supply fans are marked with the letter "s" and those of the exhaust fans with the letter "r". Each engine is described with two numbers: the first one specifies the fan number in the set, the second one is in the ModBUS network. The addresses of each fan should be confirmed in the diagram generated together with the AHU selection card. In our example below, engine 1 has address 2, engine 2 has address 5.

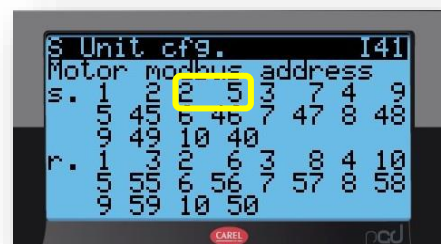
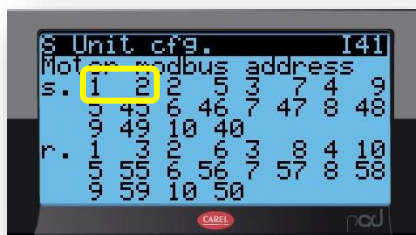

We go to the screen I43, available only for EC motors. We set the rotational speed for nominal efficiency, read from the selection card. In our example, 3211 rpm for supply and 3170 for exhaust.

The controller treats the set speed as the base to which it refers speed settings in individual AHU modes (with CAV and VAV off) - expressed in %. When the CAV or VAV functions are enabled, the set value is the upper limit of the rotational speed achieved by the fan. This speed is usually less than the factory default maximum engine speed.

On the next screen (I44) we can set a reserve increasing the maximum rotational speed in relation to

Fan PLUG_VS_630_AF_Px 2

Total Static Pressure	732 Pa	Impeller efficiency: Static / Total	64 %/73 %
Dynamic pressure	111 Pa	Shaft power	5.54 kW x 2
External pressure	350 Pa	Working revolutions	1672 1/min
Total Pressure	843 Pa	Fans Connection Standard	FLX2 (Flanged)

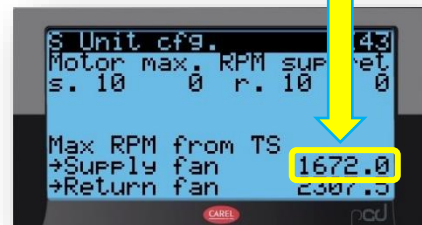

the speed at the nominal operating point. The function can be used to compensate for additional flow resistance in a ventilation system or with dirty filters.

4.7.4 Programming EC motors

Next, we will program communication and operating parameters of EC motors via the AHU controller.

ATTENTION

Each EC motor is independently configured with the supply voltage off for the other motors. We switch on the supply voltage of the first supply fan.

We go to screen I15, change the engine address from the factory No. 1 to the address No. 2 corresponding to the first supply fan. Then we activate the automatic programming function and after confirmation with the "Enter" button, automatic engine programming begins. The process usually takes several minutes. When the process is completed, we will see the "Ready" message.

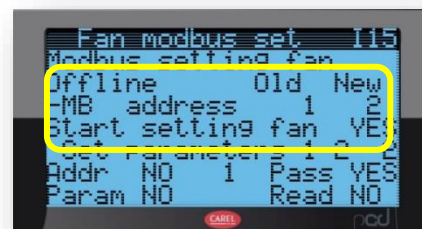

The correctness of the motor data can be checked on the I16 screen, available immediately after the programming process.

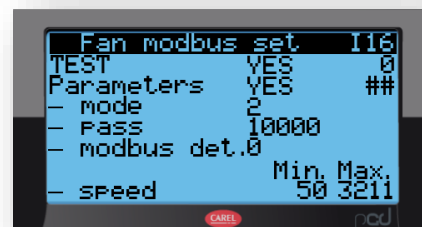

A correctly programmed motor must be turned off (with corresponding fuse) and then the next fan must be turned on. We return to screen I15, set the destination address of this motor and re-enable automatic programming. Repeat this for all engines, remembering to set the right addresses.

We remember that we start configuring the next engine after completing the full procedure for the previous one.

If the AHU is equipped with a rotary heat exchanger, after programming the last fan, carry out the heat exchanger programming procedure described in section 4.7.5. If the AHU is not equipped with a rotary heat exchanger, after programming the last fan, switch on the voltage supplying all fans and other AHU components and use the "Set" module to set the operating parameters (temperature, capacity, etc.). These activities are described in chapter 5 of the manual.

After this, AHU is ready to work.

4.7.5 Configuration of communication with a rotary heat exchanger

After programming all fan motors, we again go to the screen "I03", in which we program the type of rotary exchanger motor. Up to AHU VVS300, the exchangers are equipped with EC motors, above this size with AC motors with inverters. Below is a description of the procedure for setting up communication with both.

Rotary heat exchangers with EC motors

The EC motor in the rotary heat exchanger is factory set to control the 0-10V signal, in our AHU it is controlled after the ModBUS protocol, so we need to change these settings from the controller level.

In the "Rotor VFD" line select the EC motor type, then turn on the voltage supplying the motor and go to screen I15.

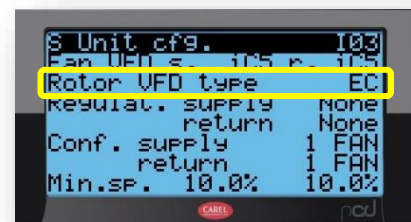

In the rotary exchanger motor, the correct address 4 is already factory set. Therefore, we set the same values of the "Old" and "New" parameters, then in the line below we activate the start of the automatic programming procedure, which aims to change the way the control signal is received from 0-10V on ModBUS.

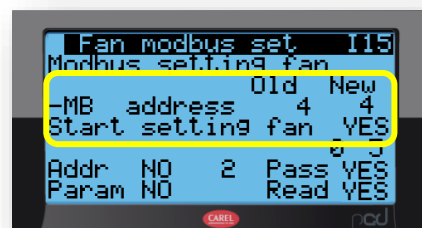

The procedure ends with the "Done" message.

After programming the rotary heat exchanger, switch on the voltage supplying all fans and other AHU components and use the "Set" module to set the operating parameters (temperature, capacity, etc.).

After this, AHU is ready to work.

Rotary heat exchangers with AC motors

The inverter programming procedure is described in chapter 2.4.6 of this manual. The controller programming procedure is limited to setting the inverter type on the I03 screen.

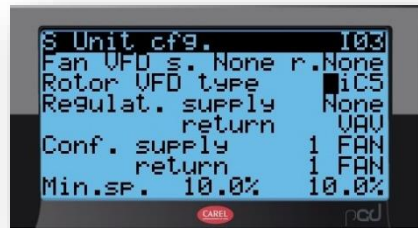

After confirmation, AHU is ready to work.

5 Use of AHU

5.1 Setting the operational parameters (temperature, humidity, efficiency, etc.)

The "SET" module is used to change the user parameter settings.

The first screen is for displaying the active settings.

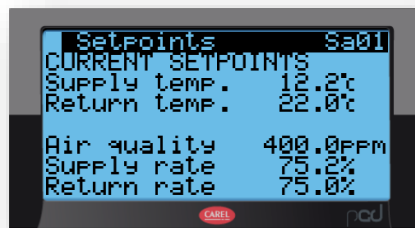

On the next screens we set the required parameters (depending on the AHU configuration: temperature, humidity, CO2, supply and exhaust air efficiency). Examples of screens are shown below.

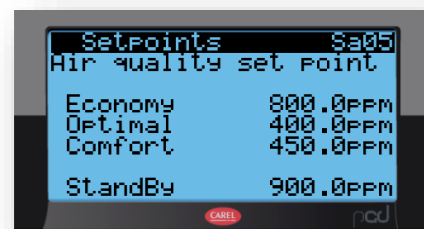



When everything is ready, we can turn the AHU on.

Attention:

Changes to other AHU operating parameters not listed above should only be made in justified cases and should be carried out by trained persons with relevant experience. It is recommended that these activities be carried out by the VTS Service Department. Changing these parameters by persons without appropriate training may damage the device and void the warranty, and may also threaten the User's safety.

If such a need arises, strictly follow the advanced instructions contained in the device's technical documentation.

The above applies to configuration changes of the VTS controller and other electronic devices that are an integral part of the delivered device.

5.2 Switching on the AHU, changing the operating modes

Turning on AHU (one of three modes) is done by pressing the Prg button several times and confirming it with the "Enter" button.



5.3 Viewing current operating parameters

The "Info" module is used to view the AHU operating parameters. Its operation does not require much skill. Scrolling between screens is done using the arrows.

Sample screens:

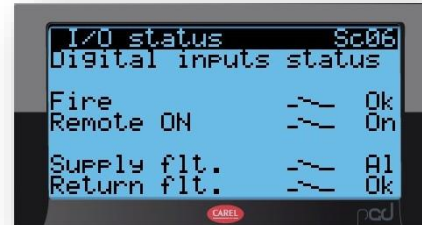

5.4 Alarms

If an alarm or alarms occurred after turning on the AHU (illuminated upper left HMI Advanced panel button), check what is causing it by pressing the illuminated alarm button. The list of alarms can be scrolled with the arrows. If the cause of the alarm stops, hold down the alarm button for 3 seconds to clear it.

If you do not know the reason for the alarm and it remains permanently active, contact the service.

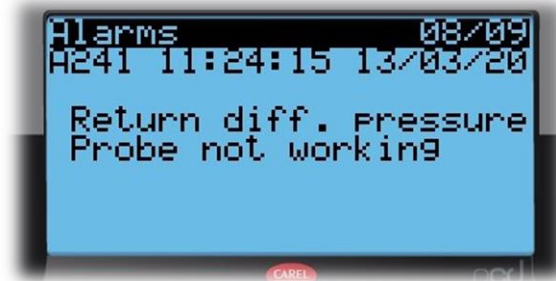

5.5 Setting the weekly clock

The controller allows you to set a weekly work schedule. Programming is done using the Sa09, Sa10 and Sa11 screens. Examples of settings are shown below.

